

# FRESHER

## WALL VENTS

### Features

- Efficient energy saving supply ventilation in flats, houses, cottages, social and commercial spaces.
- Coarse and fine filters ensure fresh filtered air supply to premises.
- Various operation modes and regulated air exchange create individually controlled microclimate.
- Organization of the air supply system with centralized control based on several ventilation units.



**Air flow:**  
up to 50 m<sup>3</sup>/h  
14 l/s



**Power:**  
from 3.8 W  
**SFP:**  
from 0.48 W/l/s



**Noise level:**  
from 13 dBA



**NEW**



### Design

The ventilator consists of a cartridge with filters, an air duct with sound absorbing material, an indoor unit with a decorative front panel and an outer ventilation hood. The cartridge consists of an energy efficient EC fan and filters that ensure coarse and fine filtration of supply air. The indoor unit is in the basic version equipped with automatic shutters that close during the

ventilator standstill and prevent air backdraft. The outer ventilation hood is used to prevent direct ingress of water and other objects to the ventilator. A remote control, an extended air duct (700 mm) and different external grilles are optionally available for the Fresher 50 units.

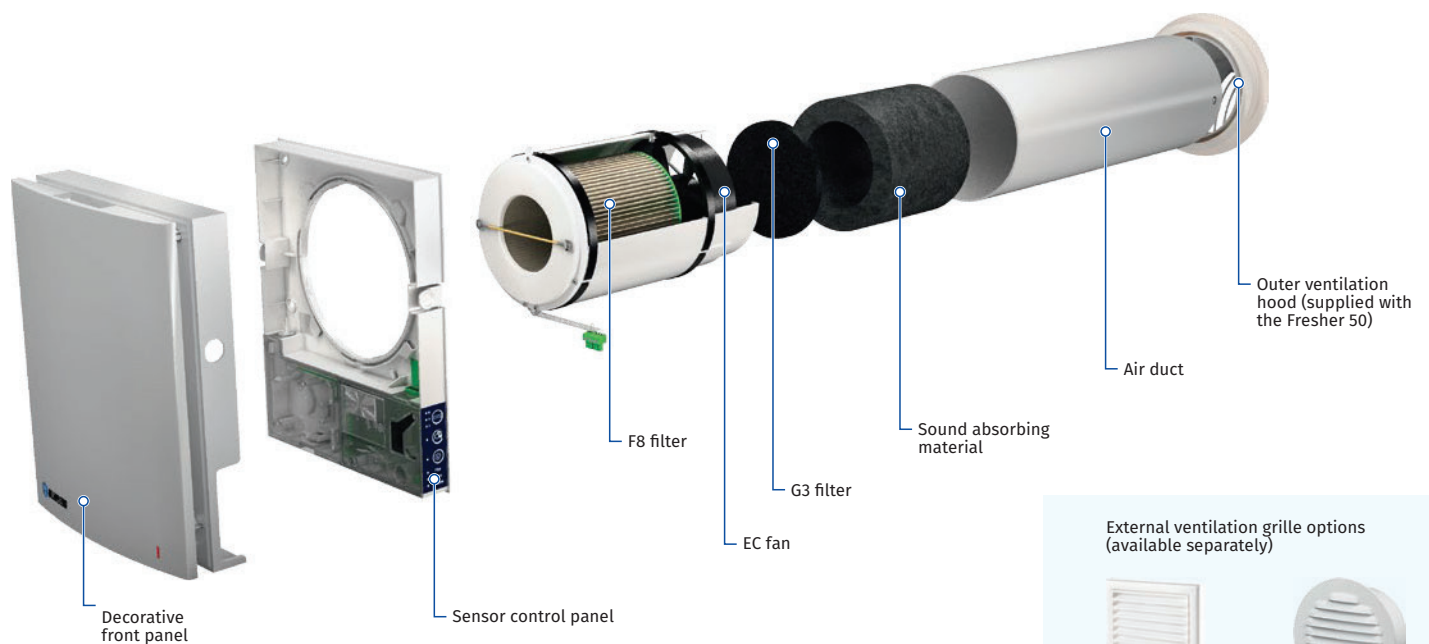

External ventilation grille options  
(available separately)



Decor  
185x185/150s



Decor  
150s St white



Easy maintenance.  
The indoor unit can be opened applying a light pressure from both sides



The built-in automatic air shutters prevent back air draft

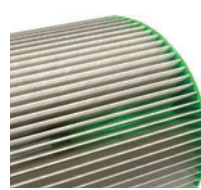

One of the highest air cleaning efficiency ratings on the market through the use of a modern filter system



The specially designed front panel provides 100 % tightness and wind protection

# FRESHER

## WALL VENTS

### Control

The ventilator can be operated with the sensor control panel on the unit casing or with the remote control (FB Fresher 50).

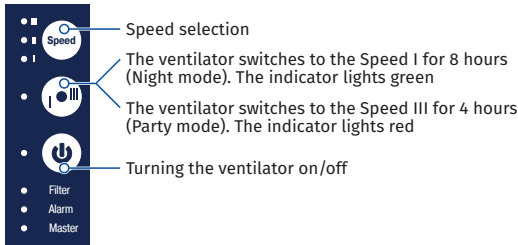

### Remote control

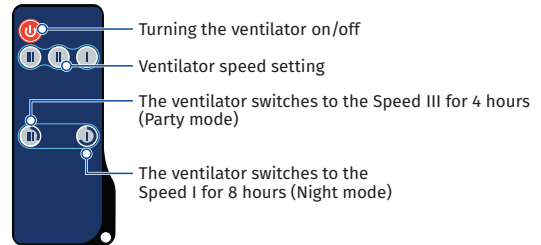

The ventilator design enables connecting any external controls, such as a humidity sensor, an external CO<sub>2</sub> sensor or a switch. Connection of several ventilators in series provides effective, optimal ventilation. The first unit

in series becomes the master unit. Ventilation mode is controlled via the control panel on the master unit. The signal from the remote control is received by the first ventilator (master) only.

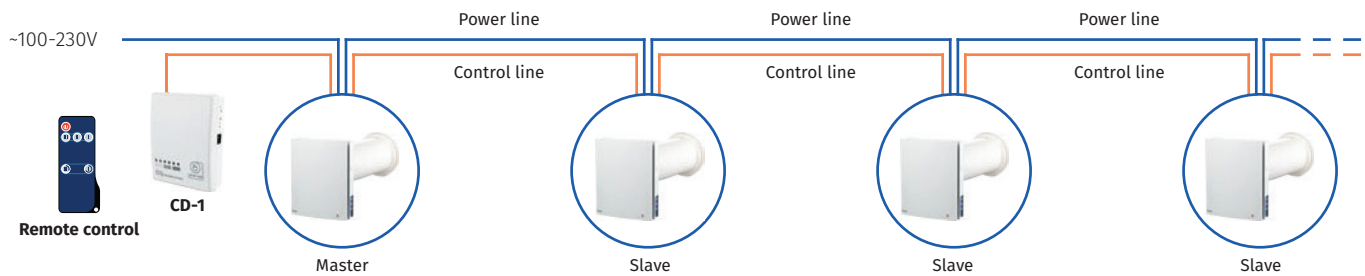

### Mounting

The unit is designed for through-the-wall mounting into a round hole provided in the outer wall. The unit installation in new-construction buildings is carried out in two phases:

1. Preassembly at the stage of interior and exterior finishing of walls (installing the air duct and the outer ventilation hood, electrical cable laying)

2. Final assembly - before commissioning the house. It includes installation of the cartridge with the fan and filters as well as installation and connection of the indoor unit with the controller and air shutters.

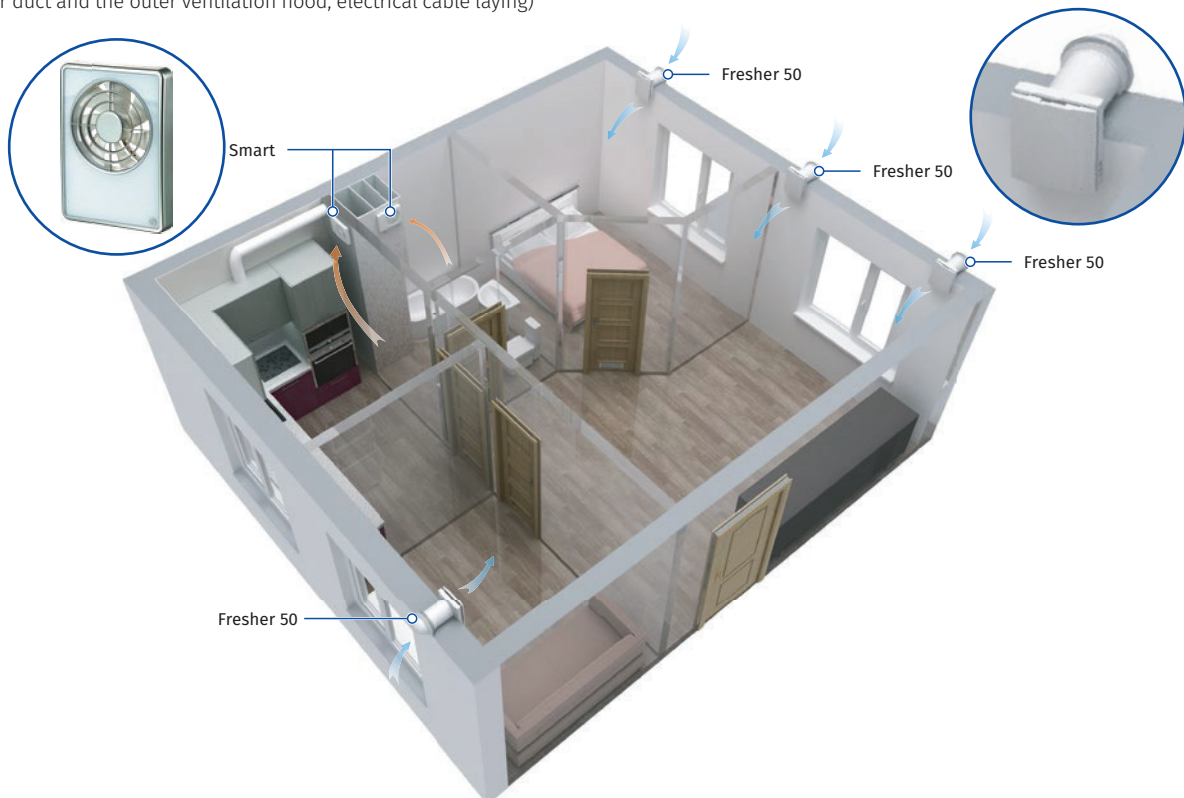

# FRESHER

## WALL VENTS

### Overall dimensions [mm]

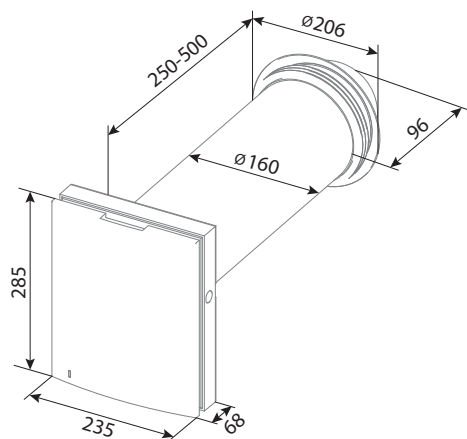

Fresher 50

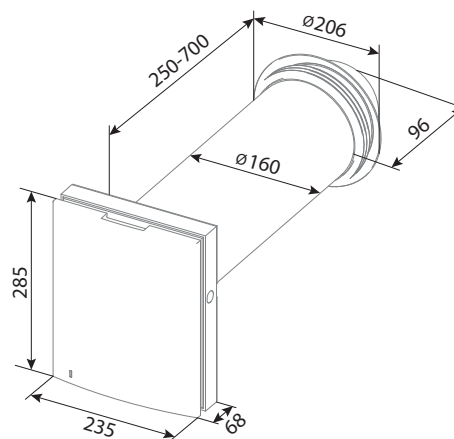

Fresher 50 L

### Technical data

Model	Fresher 50 / Fresher 50 L		
	I	II	III
Speed			
Voltage [V/50 (60) Hz]		1~100-240	
Power [W]	3.8	4.7	7.4
Current [A]	0.031	0.039	0.061
Air flow [m <sup>3</sup> /h (l/s)]	20 (6)	35 (10)	50 (14)
SFP [W/l/s]	0.68	0.48	0.53
Transported air temperature [°C]		from -30 to +50	
Noise level, 1 m [dBA]	22	29	32
Noise level, 3 m [dBA]	13	20	23
Outdoor noise attenuation [dBA]		41	
PM 2.5 removal efficiency [%]		98	
Ingress protection		IP24	

### Ecodesign parameters

Trade mark	BLAUBERG					
Model	Fresher 50					
Specific energy consumption (SEC) [kWh(m <sup>2</sup> a)]	Cold		Average		Warm	
	-53.2	A+	-26.1	B	-10.6	E
Type of ventilation unit	One-directional					
Type of drive installed	Multiple-reduction drive					
Type of heat recovery system	No					
Thermal efficiency of heat recovery [%]	n/a					
Maximum air flow [m <sup>3</sup> /h]	50					
Power [W]	7					
Sound power level [dBA]	40					
Reference flow rate [m <sup>3</sup> /s]	0.01					
Reference pressure difference [Pa]	n/a					
Specific power input (SPI) [W/m <sup>3</sup> /h]	0.134					
Control typology	Local demand control					
Maximum internal leakage rates [%]	n/a					
Maximum external leakage rates [%]	2.7					
Internet address	<a href="http://www.blaubergventilatoren.de/">http://www.blaubergventilatoren.de/</a>					
The annual electricity consumption (AEC) [kWh electricity/a]	Cold		Average		Warm	
	0.9		0.9		0.9	
The annual heating saved (AHS) [kWh primary energy/a]	Cold		Average		Warm	
	55.4		283		12.8	

# FRESHER

## WALL VENTS

Designation key				
Fresher	50	_: 500 L: 700	_: hood by default 1: grille Decor 150s St white 2: grille Decor 185x185/150s	_: no remote control FB: remote control is included
Model	Air flow [m³/h]	Air duct length [mm]	External grille type	Option

### Accessories

Accessory name		Description
FP Fresher 50 F8		Filter kit: G3 filter (1 pc) + F8 filter (1 pc)
FB Fresher 50		Remote control
CD-1		CO <sub>2</sub> sensor with LED indication and on/off button
CD-2		CO <sub>2</sub> sensor
HR-S		Room humidistat